

RITCHIE Specs

Everything about Equipment

HYSTER H50FT GAS FORKLIFT

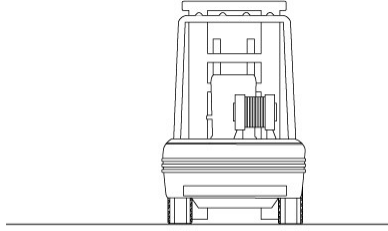
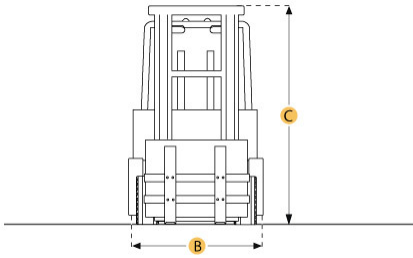

Dimensions

A. LENGTH TO FORK FACE	8.4 ft in	2559 mm
B. OVERALL WIDTH	3.8 ft in	1157 mm
C. OVERALL HEIGHT - MAST LOWERED	7.1 ft in	2170 mm
D. WHEELBASE	5.3 ft in	1623 mm
E. GROUND CLEARANCE	6.3 in	160 mm
F. HEIGHT TO TOP OF OVERHEAD GUARD	7.1 ft in	2160 mm
G. MAX FORK HEIGHT	10.8 ft in	3292 mm

MAST

H. MAST TIP FORWARD	6 degrees
I. MAST TIP REAR	10 degrees

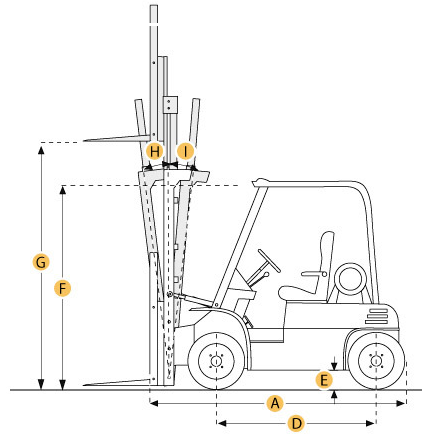

RITCHIE Specs

Everything about Equipment

HYSTER H50FT GAS FORKLIFT

Specification

Engine		
MAKE	Mazda	
MODEL	FE	
POWER	46 hp	34.3 kw
TORQUE	104 lb ft	141 Nm
DISPLACEMENT	121.9 cu in	2 L
TORQUE MEASURED @	1800 rpm	
NUMBER OF CYLINDERS	4	
FUEL TYPE	Gas	
Operational		
OPERATING WEIGHT	8750.1 lb	3969 kg
TIRE TYPE	Pneumatic	
NUMBER OF FRONT WHEELS	2	
NUMBER OF REAR WHEELS	2	
MAX SPEED	7.4 mph	11.9 km/h
MAST		
LOAD CAPACITY	5000.1 lb	2268 kg
LOAD CENTER	24 in	610 mm
MAST TIP FORWARD	6 degrees	
MAST TIP REAR	10 degrees	
MAX FORK SPREAD	43.3 in	1099 mm
LIFT SPEED	113 ft/min	34.4 m/min
LOWER SPEED	83 ft/min	25.3 m/min
Dimensions		
LENGTH TO FORK FACE	8.4 ft in	2559 mm
OVERALL WIDTH	3.8 ft in	1157 mm
OVERALL HEIGHT - MAST LOWERED	7.1 ft in	2170 mm
MAX FORK HEIGHT	10.8 ft in	3292 mm
WHEELBASE	5.3 ft in	1623 mm
TURNING RADIUS	7.1 ft in	2149 mm
HEIGHT TO TOP OF OVERHEAD GUARD	7.1 ft in	2160 mm
GROUND CLEARANCE	6.3 in	160 mm